

54th Annual



INDIANA Flower & Patio

FINER OUTDOOR LIVING SHOW SM

Since 1958, the Original Garden Show.



Mark M. Holeman, Inc.
landscape architects & contractors



March 10 - 18, 2012

Indiana State Fairgrounds • West Pavilion & Expo Hall

Presented by



A quick word from our staff

First and foremost, thank you for taking time to consider investing in the 54th annual Indiana Flower & Patio Show. We're always looking for companies, just like yours, who want to provide our 100,000+ show visitors with products and/or services to improve their outdoor spaces. Our event is a venture well worth the investment...especially in 2012!! Why? Coming March 2012, as part of the 54th annual Indiana Flower & Patio Show, we proudly present the Lifestyles Pavilion in Exposition Hall!! We understand there's more to finer living than stunning landscapes and outdoor living products...we have those covered!! We understand homeowners have many other wants, needs and desires when it comes to choosing what best fits their lifestyle. We're simply expanding our ability to engage, entertain, excite and educate our show visitors with more variety of products and services, interactive exhibits and hands-on activities for the whole family!!

You'll find below lists of the types of exhibitors we're looking for to fill the Lifestyles Pavilion...expanding on the idea of finer outdoor living AND including new exhibitors, maybe just like you, who want to help our show visitors enjoy their lifestyle to its fullest!!

Grow! This area will host more nurseries, greenhouses, specialty plants and flowers, horticulture clubs, sustainable elements and/or exhibits with a green focus;

Community! This area is being developed for our not-for-profit friends who simply need to get in front of our audience to make connections and find volunteers; also, farmers markets, any business with a Made in Indiana product, relevant local publications, etc...;

Family Fun! Anything goes in this area...as long as it relates to all things family and fun! Playground equipment, pools, travel destinations, party supply stores, getaways, museums, etc...we're even bringing back the playground;

Taste! Wineries, breweries, gourmet/specialty food shops, kitchen accessories, local and destination farms, producers and restaurants, etc...if you can eat it, cook with it, drink it...you belong here;

Indulge! For this area we're looking for quality merchandise... pottery, dishware, jewelry, clothing, lotions/soaps, bags, perfumes, accessories, etc...a retail shopping paradise;

Renew! Spas, surgeons, make-up, fitness, saunas, hot tubs... healthy living products and services;

Living! Interior design, movers, builders, home décor, realtors, bedding, flooring, furniture, appliances, home security, kitchen, bath, etc...anything improving the finer indoor living areas or experiences of our show visitor!

As you can see, we are very excited about the 2012 theme "Let Us Entertain You!", and are taking it very seriously! Our plan is to place smiles on every face in the show...creating an atmosphere that's most conducive for you to sell, sell, sell!! Best of all, we are always ready, willing, able and more than happy to help however we can!!

Kim Hirschfeld

Donell Heberer Walton

Staff photos and bios available at IndianaFlowerAndPatioShow.com

Exhibitor Testimonials

“For 16 years, HSI and the South Bend Chocolate Company have made a sweet combination! The face-to-face marketing opportunities at the show have built us into Indiana's chocolate company. Great staff, great customers, great marketing!”

Mark Tarner, *The South Bend Chocolate Company*

“This show always brings good, quality leads for us.”

Mark Heinzman, *Heinzman Lights at Night*

“We have participated for over 20 years and it has always been a great show. I love the fact I see & sell to customers outside my local area. These are sales I would never be able to get from my store!”

Andy Brogden, *Village Clock Shop*



Visit our Web site for more customer testimonials at IndianaFlowerAndPatioShow.com

Exhibitor Information

Move-In

Wednesday, March 7: 9:00 AM – 8:00 PM
 Thursday, March 8: 9:00 AM – 8:00 PM
 Friday, March 9: 9:00 AM – 12:00 PM
 No vehicle drive-in allowed on Friday, March 9th.

Move-Out

Sunday, March 18: 5:00 PM – 9:00 PM
 Monday, March 19: 8:00 AM – 3:00 PM



2012 Booth Fees

10' x 10'..... \$1,690
 10' x 20'..... \$3,380
 20' x 20'..... \$4,890
 All corners are an additional \$200 each.

Booth Fees Include

- Back Booth Drape and ID Sign
- 500 Watt Electric Outlet
- Listing in Official Show Directory (if accepted by January 16, 2012)
- Exhibitor Credential Tickets/Parking Passes
- 24-Hour Security

Presented by



Expo Hall Lifestyle Pavilion

Floor Plan, Indiana State Fairgrounds

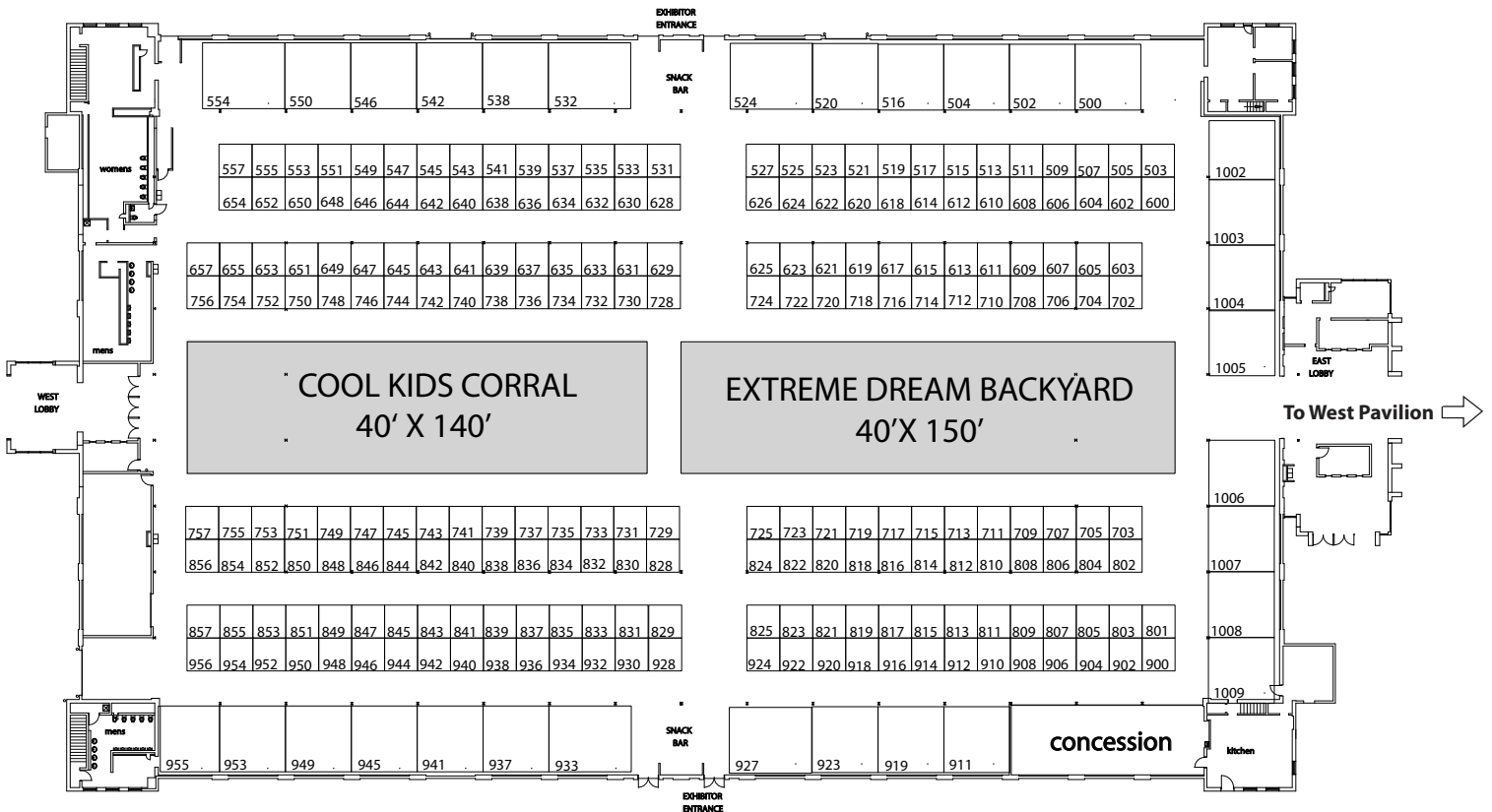

West Pavilion

Floor Plan, Indiana State Fairgrounds

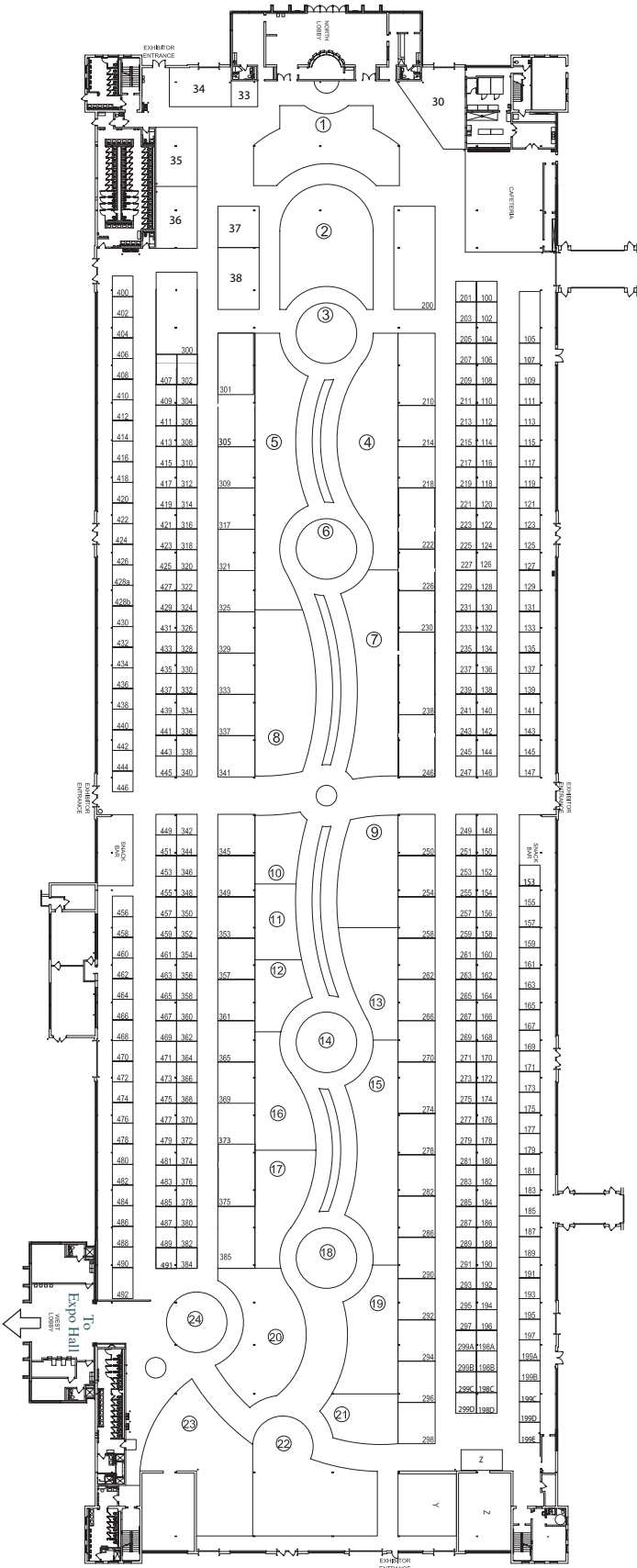

General Information

Show Dates

Saturday, March 10 – Sunday, March 18, 2012
 Saturday, March 9 – Sunday, March 17, 2013

Location

1202 E. 38th St. Indianapolis, IN 46205
 Indiana State Fairgrounds
 West Pavilion & Expo Hall

Show Hours

Monday–Friday: 10:00 AM – 9:00 PM
 Saturdays: 10:00 AM – 9:00 PM
 Sundays: 10:00 AM – 5:00 PM

Who Attends our Show

- **\$78,000** average household income
- **91%** between 25-54 years of age
- **85%** will make future purchases based on what they saw at the show
- **71%** make a major purchase at show or within 30 days
- **94%** are homeowners

A Few Items to Know

- Floor covering is strongly recommended.
- Booth layout **MUST** comply with diagram shown, unless prior written approval is granted by show management.
- Eight-foot sidewalls prohibited without prior approval.
- Absolutely **NO** handmade signs.
- No plastic skirting.
- Exhibitors must decorate in the theme/spirit of the show.
- Booths will be graded and judged.
- Booths must be manned at all times.
- Certificate of Insurance is strongly suggested.
- Due to extensive garden construction, no aisle carpet is used.

There are no sidewalls - this is just an illustration of an acceptable product display.

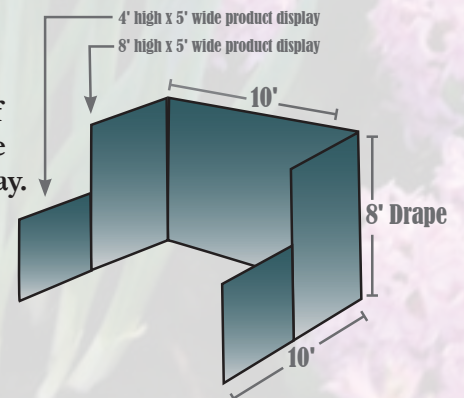



Application for Approval to Exhibit:
54th Annual Indiana Flower & Patio Show March 10th-18th, 2012

Company Name: _____ Date _____
Contact Name: _____
Address: _____
City: _____ State: _____ Zip: _____
Telephone: _____ Fax: _____ Cell/Other: _____
E-Mail: _____ Website: _____
Facebook: (Y/N) _____ Twitter: (Y/N) _____
How did you hear about our show? _____
Were you referred by one of our exhibitors? (Y/N) If so, by whom? _____

BOOTH REQUEST

I am interested in the following space size _____ ft X _____ ft.
If available, I prefer (check all that apply):

- Corner Booth in-line booth end cap storage

Please answer the following questions:

Table with 2 columns: YES, NO. Rows include questions about plastic skirting, handmade signs, booth requirements, decoration, manning, microphone, sign height, and other shows.

List products to be sold, displayed, or advertised. Be specific. Attach additional pages as needed. Products not listed must be removed from your booth.

Application Process: This is an application, NOT A CONTRACT. Space contracts will be issued after your space application has been reviewed and approved. To apply for space, this application must be filled out completely and returned with pictures of product and previous booth set-ups and required deposit (see payment schedule). Applications received without deposit and pictures will not be considered and will be returned. If no space is available, or if the application is rejected, the deposit will be refunded. Show management reserves the right to deny exhibit space to exhibits judged to be of inappropriate quality or character.

I have read and agree to the terms of the application process as listed above. Signature/Date _____

PAYMENT SCHEDULE: A deposit equal to 1/2 of the total booth price is required with this application. The remaining 1/2 is due on or before 1/20/12. If this application is being submitted after 1/20/12 payment in full is due with application. A 2% discount is being offered for payment in full with this application if paying by cash, check, or money order by 1/20/12.

Please complete the following, enclose deposit, required pictures, and return:

Table with 2 columns: Total cost of space size requested, Less 2% discount if applicable, Add optional items, Deposit included with this application, Remaining Balance Due. Optional items include Interactive Internet Listing \$25.00 and Floor Logo \$100.00.

- I am taking the 2% discount and paying in full with this application by 1/20/12 with cash, check or money order.
Check enclosed for payment - make checks payable to HSI Show Productions
Charge my credit card (circle one) MC / Visa / AMEX / Discover

Account# _____ Code: _____ Exp: _____
Billing Address: _____ Zip Code: _____
Signature: _____

Send remittance to: HSI Show Productions, P.O. Box 502797, Indianapolis, IN 46250
Phone (800) 215-1700 or (317) 576-9933 or FAX (317) 576-9955

Marketing Support

The Indiana Flower & Patio Show is your best opportunity to get an early jump on big spring sales. **Outstanding publicity and advertising mean more buyers for you!**

The Indiana Flower & Patio show features an outstanding, advertising and promotional campaign that brings homeowners targeted to your products. We support the show with a comprehensive advertising campaign highlighted by television, radio, newspaper, billboards, direct mail, social media and email marketing to a support database of over 10,000 fans of our show.

Adding to these facts – increased marketing programs, promotions, public relations and a continuation of our dedication to produce Indiana's most successful show whose focus is our show visitors finer outdoor living spaces – are but a few of the reasons your company should be exhibiting at the 2012 Indiana Flower & Patio Show.



2012 Showcase Garden theme:

Let us
*Entertain
you!*



P.O. Box 502797
Indianapolis, IN 46250

March 10 - 18, 2012

